

TIME DELTASERIES <TIME DELTA-C>

# ULTRASONIC FLOWMETER <Advanced type>

DATA SHEET

FSV-2, FSS, FLY

This flowmeter is a clamp-on type ultrasonic flow meter based on transit-time measuring method. Making full use of the latest electronics and digital signal processing technologies, the flowmeter is designed for 2-path system capable of simultaneously measuring 2 pipes, and energy calculation by connecting with temperature sensor, while keeping with the resistance to air bubbles. It is an effective solution for measurement and management of the energy used in energy-saving systems such as heating and air conditioning applications.

## FEATURES

### 1. Advanced function

- Improved stability and accuracy by using 2-path system
- Capability of simultaneously measuring 2 pipes by one transmitter (Difference calculation possible).
- Energy measurement in combination with temperature sensor

### 2. High accuracy

The flowmeter is designed for high accuracy (better than ±1.0% of rate) by dynamic correction of fully-developed flow profile. Reynolds Number is calculated and a meter factor (K) is automatically applied for best accuracy at all flow velocities. Further, the adoption of new sound velocity measurement system permits measurements of fluids of unknown sound velocity. Moreover, affection from fluid temperature and pressure is negligible (Auto-Temp./ Press. compensation).

### 3. Excellent resistance against aerated flow

Fuji's unique ABM feature improves measurement reliability for different flow like slurries, sludge, raw sewage and bubble-contained flow (acceptable up to air bubble of 12% volume at 1m/s velocity).

## FUNCTIONAL DIAGRAM

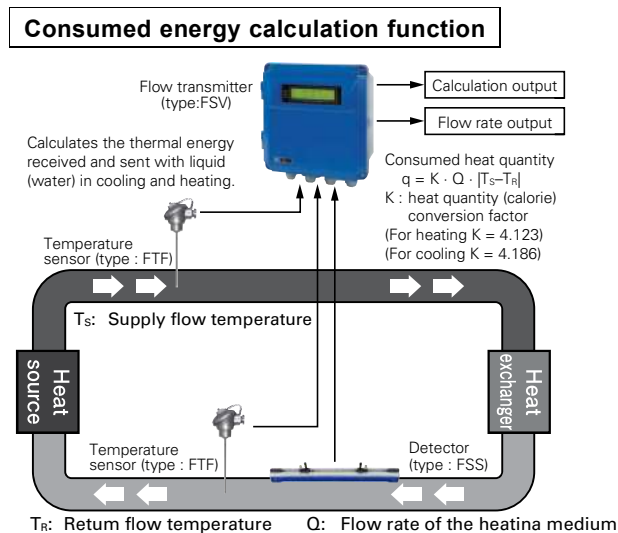

Flow transmitter (FSV)



Detector (FSSC)



Detector (FSSE)

### 4. Full variety of sensors

The flowmeter can be used with various types of sensors applicable for wide range of pipe size (ø13 to ø6000mm) and fluid temperature (-40 to +200°C).

### 5. Quick response

With the use of high-speed micro-processor suited for digital signal processing, the fast response time is realized.

### 6. Multi-lingual

The following languages are supported for display: Japanese (Katakana), English, German French, and Spanish.

### 7. Excellent performance and easy operation

LCD and function keys are allowing easy configuration and trouble shooting.

- LCD with back light
- Easy mounting of sensor
- Extendable rail type detector up to ø50 to ø1200mm
- Trouble shooting
- Easy operation with keypad on the front surface of the flow transmitter

### 2-channel measurement (for 2 pipes)

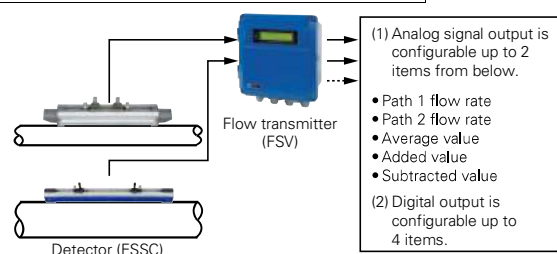

### 2-path measurement (for 1 pipe)

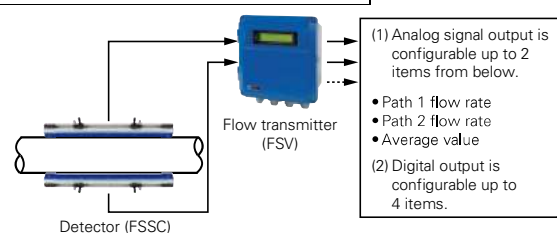

## SPECIFICATIONS

### Operational specifications

#### System configuration:

Single-path or 2-path system with a flow transmitter (Model FSV) and a detector (Model FSS) (2-pipe version is also available)

See functional diagram for the definition of 2-path and 2-pipe measurement.

Energy measurement by transmitter, detector, and resistance bulb (pt100).

Either 2-path/2-pipe measurement or energy measurement can be selected.

#### Applicable fluid:

Homogenous liquid where the ultrasonic signal can be transmitted

Bubble quantity: 0 to 12vol% (for pipe size 50A, water, velocity 1m/s)

Fluid turbidity: 10000mg/L max.

Type of flow: Fully-developed turbulent or laminar flow in a full-filled pipe

#### Flow velocity range:

0 to ±0.3 ... ±32m/s

#### Power supply: 100 to 240V AC +10%/-15%, 50/60Hz

#### Signal cable (between detector and converter):

Coaxial cable (150m max.) applicable up to 300m depending on the condition.

Heat resistance: 80°C

#### Installation environment:

Non-explosive area without direct sunlight, corrosive gas and heat radiation.

#### Ambient temperature:

Flow transmitter: -20 to +55°C

Detector: -20 to +60°C

#### Ambient humidity:

Flow transmitter: 95%RH max.

Detector: 90%RH max.

#### Grounding: Class D (100 Ω)

#### Arrester: Provided as standard at power supply

#### Applicable piping and fluid temperature:

2-pipe/energy calculation: ø13 to ø6000mm

2-path measurement: ø50 to ø6000mm

<table 1>

Detector Type	Pipe size (inner diameter) ø (mm)	Mounting method	Fluid temperature range (°C) (Note 2)	Applicable pipe material (Note 1)
FSSA	25 to 50	V method	-20 to +100	Plastic (PVC, Others)
	50 to 225			
FSSC	50 to 600	V method	-40 to +120	Plastic (PVC, Others)
	300 to 1200	Z method		
FSSD	13 to 100	V method	-40 to +100	Metal pipe (Stainless steel, Carbon steel, Copper, Aluminum, Others)
FSSE	200 to 1000	V method	-40 to +80	
	500 to 6000	Z method		
FSSH	50 to 200	V method	-40 to +200	
	150 to 400	Z method		

Note1) Please select the FSSC type or FSSE type if following condition.

- When pipe material is PP and thickness is 15mm or more
- When pipe material is PVDF and thickness is 9mm or more
- When pipe material is cast iron pipe, lining pipe, old steel pipe or others through which the ultrasonic signal could not be transmitted easily.

Lining material: Tar epoxy, mortar, rubber, etc.

\* If the lining is not properly glued to a pipe, the measurement may be impossible.

Note2) When silicon grease is used as acoustic coupler, Fluid temperature limit is 0 to 60°C no matter what detector is selected.

Note3) Heat-resistant shock temperature: for 30 minutes at 150°C For the detector FSSA or FSSC

### Performance specifications

#### Rated accuracy:

<table 2>

Detector Type	Pipe size (diameter) ø (mm)	Flow velocity (m/s)	Accuracy	
			Plastic pipe	Metal pipe
FSSA	25 to 50	2 to 32	±2.0% of rate	—
		0 to 2	±0.04m/s	—
	50 to 225	2 to 32	±1.0% of rate	±2.0% of rate
		0 to 2	±0.02m/s	±0.04m/s
FSSC	50 to 200	2 to 32	±1.5% of rate	
		0 to 2	±0.03m/s	
	200 to 1200	2 to 32	±1.0% of rate	
		0 to 2	±0.02m/s	
FSSD	13 to 50	2 to 32	±1.5% to ±2.5% of rate	
		0 to 2	±0.03 to ±0.05m/s	
	50 to 100	2 to 32	±1.5% of rate	
		0 to 2	±0.03m/s	
FSSE	200 to 300	2 to 32	±1.5% of rate	
		0 to 2	±0.03m/s	
	300 to 1200	0.75 to 32	±1.5% of rate	
		0 to 0.75	±0.0113m/s	
	1200 to 6000	1 to 32	±1.0% of rate	
		0 to 1	±0.02m/s	
FSSH	50 to 300	2 to 32	±1.0% of rate	
		0 to 2	±0.02m/s	
	300 to 400	0.75 to 32	±1.0% of rate	
		0 to 0.75	±0.0075m/s	

#### Response time:

1s (standard mode)

0.2s as selected (quick response mode)

#### Power consumption:

30VA max. (AC power supply)

### Functional specifications

#### Analog signal:

4 to 20mA DC (2 points maximum)

Load resistance: 600Ω max.

#### Digital output:

Forward total, reverse total, totalized energy, temperature alarm, and cooling/heating modes, alarm, acting range, flow switch, total switch

assignable arbitrarily

Transistor contact (isolated, open collector)

- Outputs: 4 points max.
- Normal: ON/OFF selectable
- Contact capacity: 30V DC, 50mA
- Output frequency: 100P/s max. (pulse width: 5, 10, 50, 100, 200, 500, 1000ms)

#### Serial communication (option):

RS-485 (MODBUS), isolated, arrester incorporated

Connectable quantity: 31 units

Baud rate: 9600, 19200, 38400bps

Parity: None/Odd/Even selectable

Stop bits: 1 or 2 bits selectable

Cable length: 1km max.

Data: Flow velocity, flow rate, forward total, reverse total, status, energy flow, energy calculation for cooling system, energy calculation for heating system, temperature, etc.

#### Display device:

2-color LED (Normal: green, Extraordinary: red)

2 indicator lamps (for path 1 and 2)

LCD with 2 lines of 16 characters and back light

#### Indication language:

Japanese (Katakana)/English/French/German/Spanish (changeable)

**Flow velocity/flow rate indication:**

Instantaneous flow velocity, instantaneous flow rate indication (minus indication for reverse flow)  
 Numerals: 8 digits (decimal point is counted as 1 digit)  
 Unit: Metric/Inch system selectable

Velocity	m/s
Flow rate	L/s, L/min, L/h, L/d, kL/d, ML/d, m <sup>3</sup> /s, m <sup>3</sup> /min, m <sup>3</sup> /d, km <sup>3</sup> /d, Mm <sup>3</sup> /d, BBL/s, BBL/min, BBL/h, BBL/d, kBBL/d, MBBL/d

**Energy indication:**

indication of energy consumption  
 energy consumption of heat medium  
 energy flow:  
 MJ/h, GJ/h, BTU/h, kBtu/h, MBtu/h, kW, MW  
 totalized energy:  
 MJ, GJ, BTU, kBtu, MBtu, kWh, MWh  
 J: Joule  
 BTU: British thermal unit  
 W: Watt  
 Note1) Minus-totalization of thermal energy is not available when the flow direction is reverse.  
 Note2) The amount of thermal energy is detected as zero when the difference in temperature is 0.5°C or less.

Temperature indication: °C, K

Operation mode:

Cooling mode, Heating mode, Cooling/heating automatic change mode

Temperature input:

Input type: Resistance bulb (Pt100, 3-wire)

Input range: -40 to +200°C

Indication accuracy (at 23°C): ±1.0% FS

**Configuration:** Fully configurable from the 4-key pad (ESC, △, ▽, ENT)

**Zero adjustment:** Set zero/Clear available

**Damping:** 0 to 100s (every 0.1s) for analog output and flow velocity/flow rate indication

**Low flow rate cutoff:**

0 to 5m/s in terms of flow velocity

**Alarm:** Digital output available for Hardware fault or Process fault

**Output setting:** <table 3>

Measuring mode	Output type	Analog signal	Digital output
2-path	Path 1 flow rate Path 2 flow rate Average value	2 points max. (select from the left column)	4 points max.
2-pipe	Path 1 flow rate Path 2 flow rate Average value Added value Subtracted value	2 points max. (select from the left column)	4 points max.
Energy flow	Path 1 flow rate Energy flow	2 points max.	4 points max.

**Burnout:** Analog output: Hold/Overscale/Under-scale/Zero selectable

Flow rate total: Hold/Count selectable

Burnout timer: 0 to 100s (every 1s)

**Bi-directional range:**

Forward and reverse ranges configurable independently.

Hysteresis: 0 to 10% of working range

Working range applicable to digital output

**Auto-2 range:**

2 forward ranges configurable independently

Hysteresis: 0 to 10% of working range

Working range applicable to digital output

**Flow switch:**

Lower limit, upper limit configurable independently

Digital output available for status at actuated point

**Total switch:**

Forward total switching point configurable

Digital output available when actuated

**External total preset:**

Preset total settable upon contact input setting

**Backup of power failure:**

backup by non-volatile memory

**Physical specifications****Type of enclosure:**

Flow transmitter: IP67

Detector:

FSSA, FSSC:

IP65 (When waterproof BNC connector is provided)

FSSD, FSSH: IP52

FSSE:

IP67 (Silicone rubber is filled up on the terminal block)

FSSC, FSSE (waterproofing):

IP68 (submerged resistant structure for 5days)

**Mounting method:**

Flow transmitter: Mounted on wall or by 2B pipe

Detector: Clamped on pipe surface

**Acoustic coupler:**

Acoustic coupler is a filling between detector and pipe.

Type of acoustic coupler: <table 4>

Type	Silicone rubber (KE-348W)	Silicone grease (G40M)	Silicone-free grease (HIGH Z)	Grease for high temperature (KS62M)
Fluid temperature	-40 to +150°C	-30 to +150°C	0 to +60°C	-30 to +250°C
Teflon piping	×	○	○	○

In case of Teflon piping, use grease.

**Material:** Flow transmitter: Aluminum alloy

Detector: <table 5>

Detector Type	Sensor housing	Cover	Guide rail
FSSA	PBT	—	SUS304
FSSC	PBT	—	Aluminum alloy + PBT
FSSD	PBT	—	Aluminum alloy + PBT
FSSE	PBT	SUS304	—
FSSH	SUS304	SUS304	Aluminum alloy

**Signal cable:**

• Structure: Heat-resisting high-frequency coaxial cable

• Sheath: Flame-resisting PVC

• Outer diameter: ø7.3mm

Terminal treatment: <table 6>

Cable type	FLYD
Applicable detector	FSSA, FSSC, FSSD, FSSE, FSSH
Terminal of flow transmitter side	Rod terminal ×2 Amplifier terminal (M3) ×1
Terminal of detector side	BNC connector × 1 Amplifier terminal (M4) ×1

Dimension, Mass: <table 7>

Type		Dimensions (mm)	Mass.(kg)
Flow transmitter	FSV	H240 × W247 × D134	5
Detector	FSSA	H50 × W348 × D34	0.4
	FSSC	H88 × W480 × D53	1
	FSSD	H90 × W320 × D52.5	0.6
	FSSE	H67 × W78 × D84	1.2
	FSSH	H205 × W530 × D52	1.6
Signal cable	FLYD	ø7.3mm	90g/m

**External terminal of flow transmitter:**

plug terminal

**PC Loader software**

Provided as standard

- Compatible model is PC/AT compatible instrument.
- Main functions: Software for Main unit parameter setting/change on PC
- OS: Windows 2000/XP/Windows 7 (Home Premium, Professional) or Windows 8 (Professional)
- Memory requirement: 125MB min.
- Disk unit: CD-ROM drive compatible with Windows 2000/XP/Windows 7 (Home Premium, Professional) or Windows 8 (Professional)
- Hard disk capacity: Minimum vacant capacity of 52MB or more

Note: Optional communication board (specified at the 5<sup>th</sup> digit of code symbols).

Note: Communication converter

For the PC that supports RS-232C serial interface, RS-232C - RS-485 converter is needed for connecting the PC and main unit.

For the PC that does not support RS-232C serial interface, additionally, USB - RS232C converter is also needed.

<Recommendation>

[RS-232C - RS-485 converter]

RC-770X(manufactured by SYSMEX RA)

[USB - RS-232C converter]

USB-CVRS9 (manufactured by SANWA SUPPLY)

**Conditions on straight pipe**

( D : Inside diameter of pipe)

Classification	Upstream side	Downstream side
90 bend		
Tee		
Diffuser		
Reducer		
Various Valve	 In case that flow control valve exists on upstream side.	 In case that flow control valve exists on downstream side.
Pump		

(Note) The source : JEMIS-032

# MEASURING PRINCIPLE

With ultrasonic pulses propagated diagonally between the upstream and downstream sensors, flow rate is measured by detecting the time difference obtained by the flow of fluid.

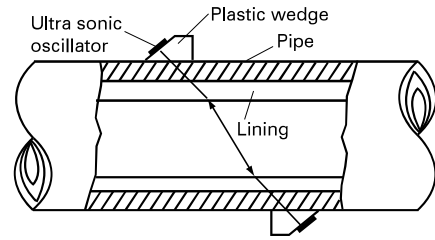
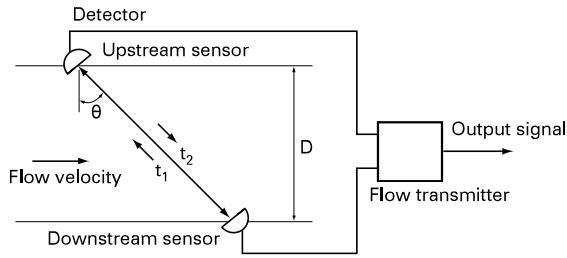

# CONFIGURATION DIAGRAM

(1) Single path system (V method)

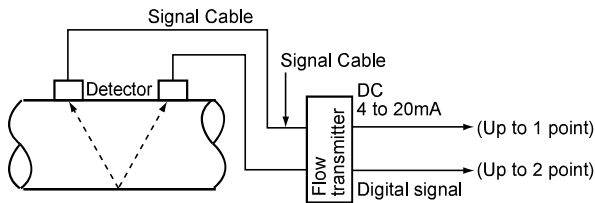

(2) Single path system (Z method)

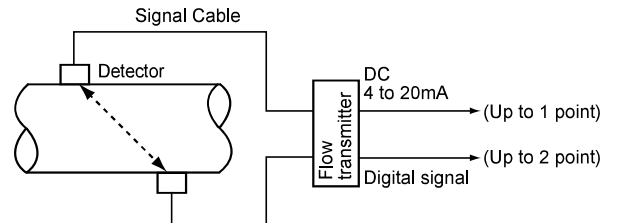

(3) 2-path system (V method)

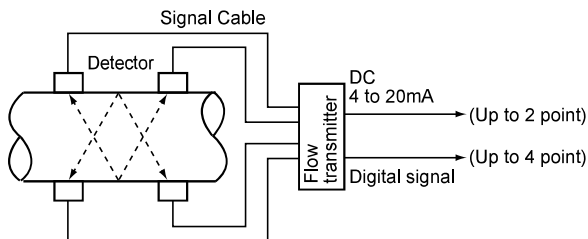

(4) 2-path system (Z method)

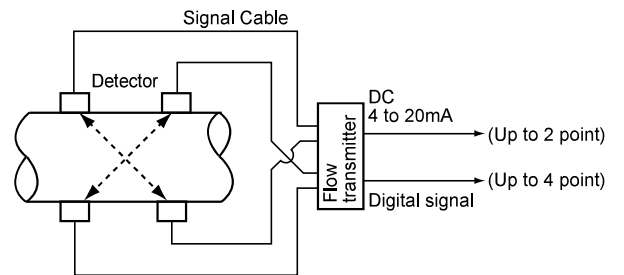

(5) 2-pipe system (V method)

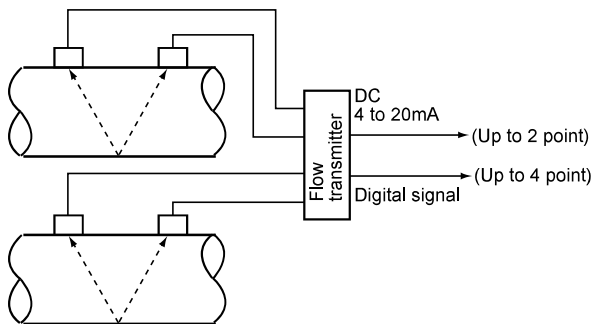

(6) 2-pipe system (Z method)

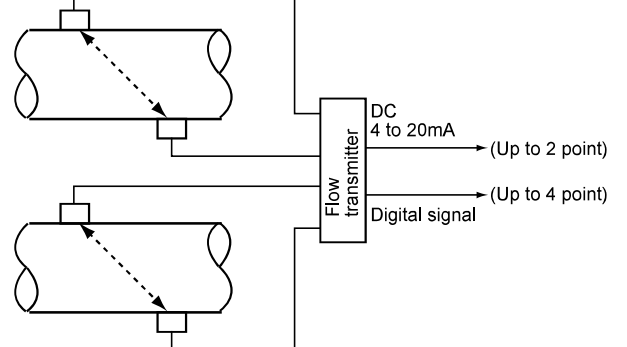

(7) Energy flow measurement (V method)

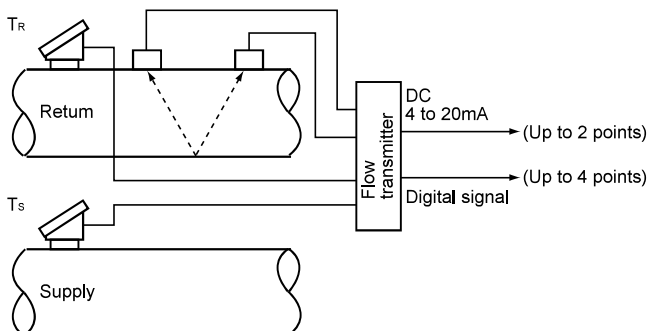

(8) Energy flow measurement (Z method)

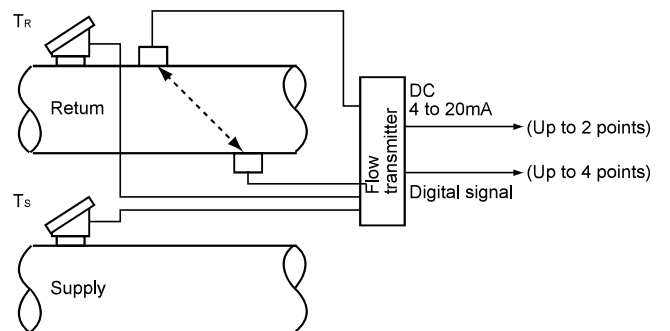

CODE SYMBOL



<Flow transmitter>

1	2	3	4	5	6	7	8	9	10	11	12	13	Description	
F	S	V					1	2	L				(Destination) (4th digit) Standard (Japanese) Standard (English)	
			S										(Communication) (5th digit) None RS485	
				Y									(Use) (6th digit) 2-path/2-pipe Single path/energy	
					A								(Power supply) (7th digit) AC100 to 240V 50/60Hz	
						1							(Case structure) (9th digit) IP67	
								L					(Wire connection port) (10th digit) Weatherproof gland provided Union (for pilica) with gland	
									Y				(Combination with explosion-proof detector) (11th digit) *1 None Provided	
										A			(Parameter setting) (12th digit) None Setting provided Setting provided + tag Tag	
											Y		(Mounting method) (13th digit) Wall mount Pipe mount	
												B		
												C		

Note 1: HumiSeal coated PCB

<Detector>



1	2	3	4	5	6	7	8	9	10	Description	
F	S	S	A	1	A	1		Y		<Senser type> (4th digits) ø25 to ø225mm (V method)	
			A							<Guide rail> (5th digits) Provided	
				1						<Mounting belt> (6th digits) None Stainless belt (1.0m x 2)	
					Y					<Acoustic coupler> (7th digit) (*2) None Silicon rubber Silicon-free grease Silicon grease	
						A					
						B					
						C					
								Y		<Watwe-proof treatment>(9th digit) None	
									Y	<Tag plate> (10th digit) None Provided	

Note 2: Normally select silicone rubber as acoustic coupler. Silicone rubber in tube (100g) is furnished. If you place an order for several units, 1 tube may suffice for every 5 units. Select silicone-free grease for semiconductor manufacturing equipment or the like that is vulnerable to silicone. The silicone-free grease is water-soluble and, therefore, cannot be used in environment exposed to water or on piping subjected to a condensation. Since the grease does not set, a periodic maintenance (cleaning, refilling every about 6 months at normal temperature) is necessary.

<Detector>



1	2	3	4	5	6	7	8	10	11	Description	
F	S	S						1		<Senser type> (4th digits) ø50 to ø1200mm	
									C	<Guide rail> (5th digits) Provided (Extendable rail type)	
										<Mounting belt> (6th digits) *3 None Stainless belt (1.5m×2) SS belt fasten with screws (1.0m×4) Wire ≤ ø1500m (5m×2)	
									Y	<Acoustic coupler> (7th digit) None Silicon rubber (KE348) Silicone-free grease (HIGH-Z) Silicone grease (G40M)	
									A		
									C		
										<Watwe-proof treatment>(9th digit) None Provided (with signal cable 10m)	
									Y	<Tag plate> (10th digit) None Provided	
									A		

\*3) Please refer to the table 9 to select the mounting belt at 6th digits.

[Table 9] How to select at 6th digits.

Mounting method	≤ø300mm	≤ø600mm	≤ø1200mm
V method	A or C	C	D
Z method	C	D	D

Explanation of the extendable rail type detector

■ Unextended condition



available pipe diameter up to ø50 to ø300mm  
<V method>

■ Extended condition



available pipe diameter up to ø600mm  
<V method>

■ Installation of the supplied rail end.



available pipe diameter up to ø1200mm  
<Z method>

Belt appearance for attachment of the detector.



<Detector>



1	2	3	4	5	6	7	8	9	10	Description
F	S	S	D	1				1	Y	<Senser type>(4th digits) ø13 to ø100mm (-40 to 100°C)
										<Guide rail>(5th digits) Provided
										<Mounting belt>(6th digits) None Stainless belt (1.5m×2) SS belt fasten with screws (1.0m×4)
										<Acoustic coupler> (7th digit) None Silicon rubber (KE348) Silicone-free grease (HIGH-Z) Silicone grease (G40M)
										<Water-proof treatment>(9th digit) None
										<Tag plate> (10th digit) None Provided

<Detector>



1	2	3	4	5	6	7	8	9	10	Description
F	S	S	E	1				1		<Senser type>(4th digits) ø200 to ø6000mm (-40 to 80°C)
										<Guide rail>(5th digits) None
										<Mounting belt>(6th digits) None Wire (≤ ø1500mm) Wire (≤ ø6000mm)
										<Acoustic coupler> (7th digit) None Silicon rubber (KE348) Silicone-free grease (HIGH-Z) Silicone grease (G40M)
										<Water-proof treatment>(9th digit) None Provided (with signal cable 10m)
										<Tag plate> (10th digit) None Provided

<Detector>



1	2	3	4	5	6	7	8	9	10	Description
F	S	S	H	1				1	Y	<Senser type>(4th digits) ø50 to ø400mm (-40 to 200°C)
										<Guide rail>(5th digits) Provided
										<Mounting belt>(6th digits) None Stainless belt (1.5m×2) SS belt fasten with screws (1.0m×4)
										<Acoustic coupler> (7th digit) None High-temperature grease (KS62M)
										<Water-proof treatment>(9th digit) None
										<Tag plate> (10th digit) None Provided

<Signal cable>

1	2	3	4	5	6	7	8	Description
F	L	Y	D				1	Type of sensor (4th digit) for FSSA, FSSE, FSSD, FSSE, FSSH
								Cable length (5,6 and 7th digit)
				0	0	5		5 m
				0	1	0		10 m
				0	1	5		15 m
				0	2	0		20 m
				0	2	5		25 m
				0	3	0		30 m
				0	3	5		35 m
				0	4	0		40 m
				0	4	5		45 m
				0	5	0		50 m
				0	5	5		55 m
				0	6	0		60 m
				0	6	5		65 m
				0	7	0		70 m
				0	7	5		75 m
				0	8	0		80 m
				0	8	5		85 m
				0	9	0		90 m
				0	9	5		95 m
				1	0	0		100 m
				1	1	0		110 m
				1	2	0		120 m
				1	3	0		130 m
				1	4	0		140 m
				1	5	0		150 m
				Z	Z	Z		Others (contact us)

### OUTLINE DIAGRAM (Unit:mm)

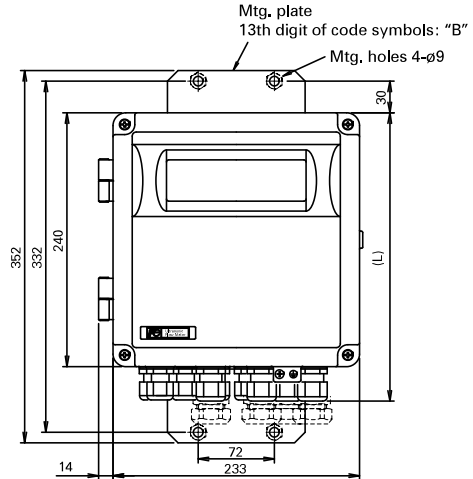
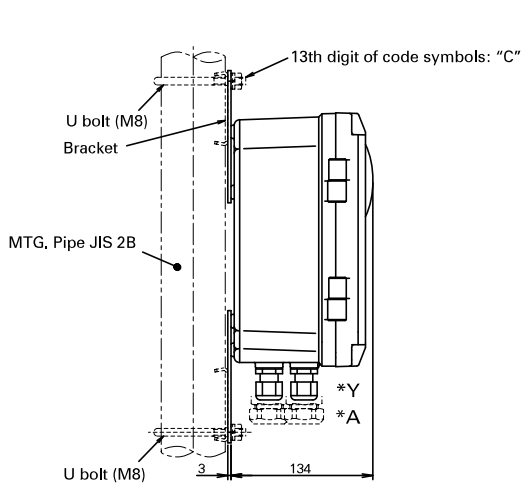

10th digit of the code symbols	Conduit connection	L	Applicable cable	
			PF1/2	PF3/8
*Y	With waterproof gland	273	ø6 to 12	ø5 to 10
*A	Waterproof gland with union plug (for plica tube PV-5#17)	294	max. ø14	

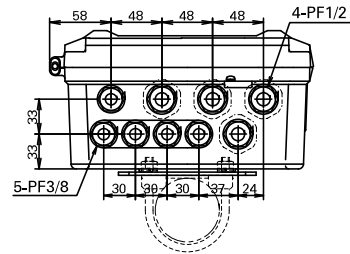

### CONNECTION DIAGRAM

<Flow transmitter>

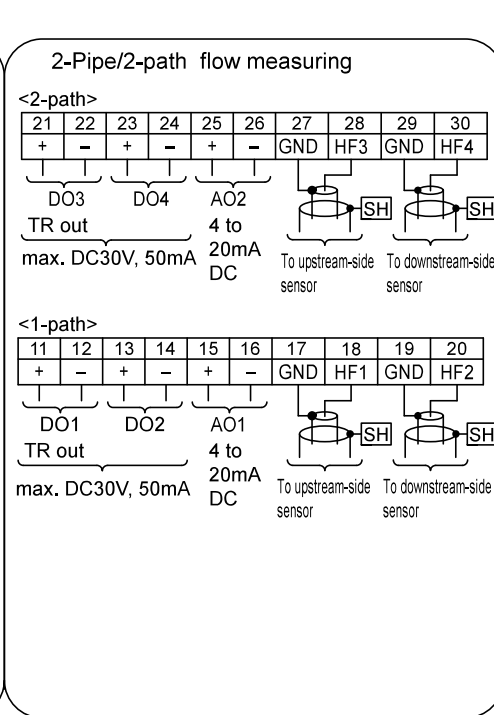
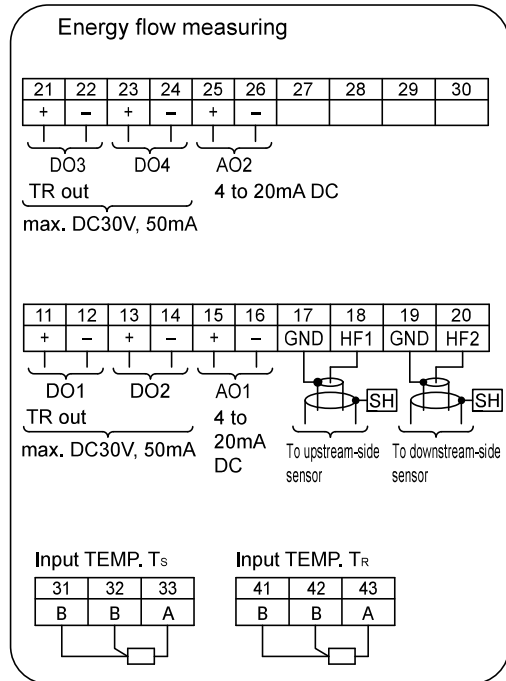

<Detector>

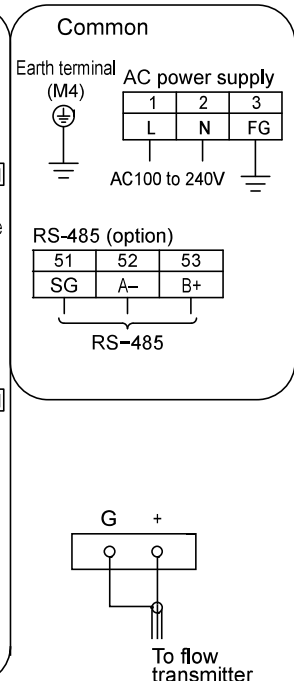

### Usable wiring material

- Wire  
Gauge: AWG20 (0.5mm<sup>2</sup>) to AWG16 (1.5mm<sup>2</sup>)  
Strip-off length: 10mm

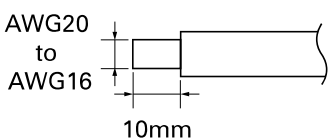

- Bar terminal  
Weidmüller  
www.weidmuller.com

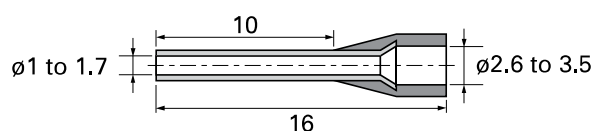



# OUTLINE DIAGRAM (Unit:mm)

## Detector : Type FSSA

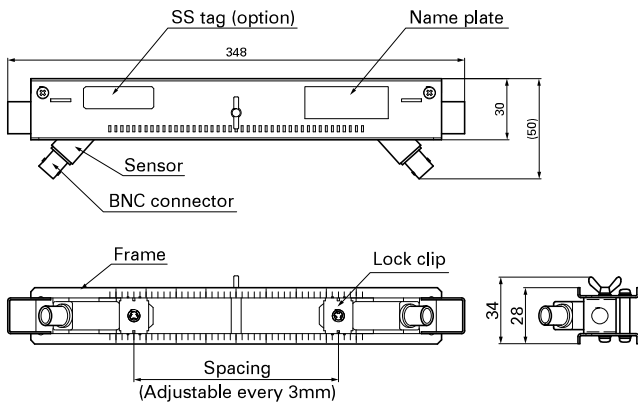

## Detector : Type FSSC

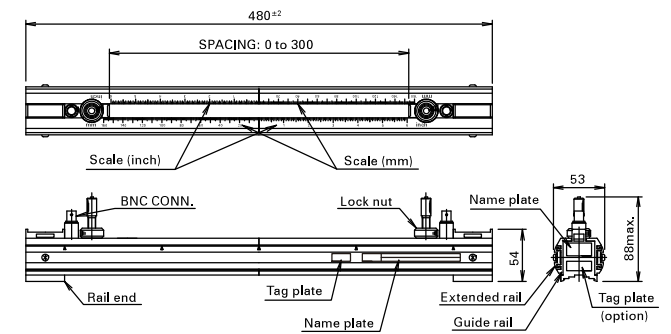

## Detector : Type FSSE

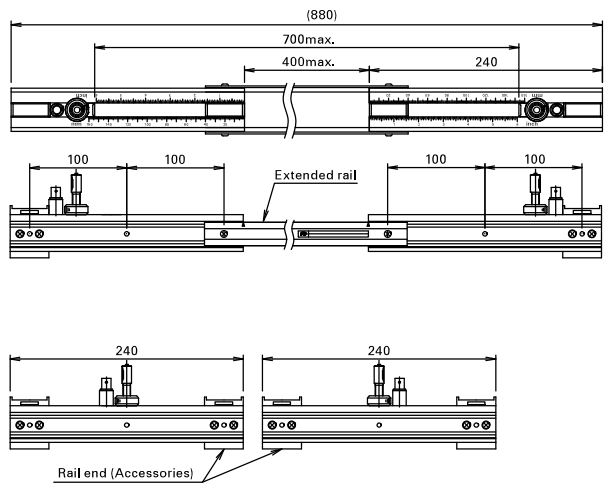
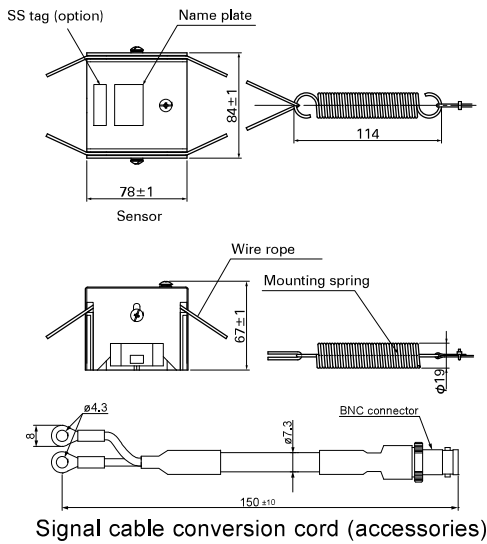

## Detector : Type FSSD

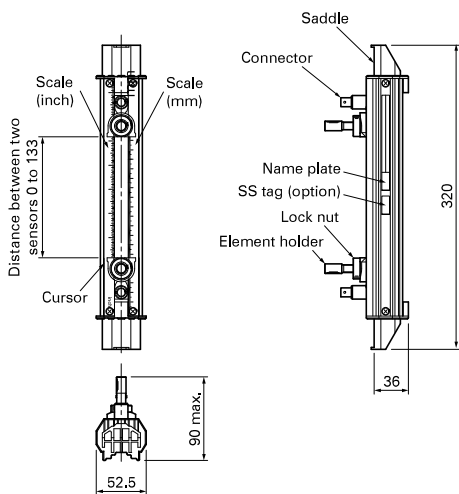

## Detector : Type FSSH

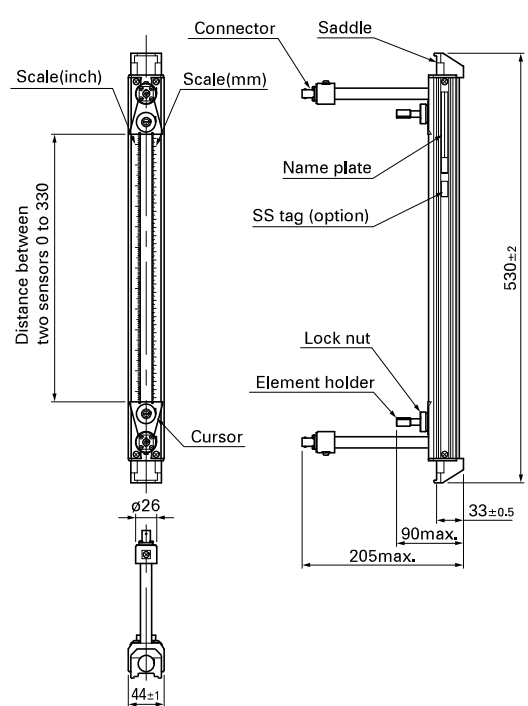

## Detector : Type FLYD

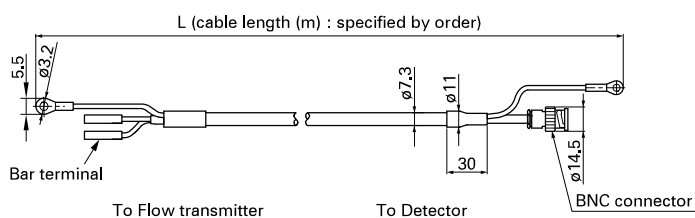

## SCOPE OF DELIVERY

- For 1-channel and 2-path version
  - Detector (Type: FSS) ×2: provided with mounting fixture and acoustic coupler according to specified code of symbol. For type FSSE, cable adapter (15cm) is also provided.
  - Flow transmitter (Type: FSV) ×1: provided with U-bolt and nuts for pipe mount.
  - Signal cable (Type: FLY) 2 pairs
  - CD-ROM (contains instruction manual, loader software)
- For energy measurement version
  - Detector (Type: FSS) ×1: provided with mounting fixture and acoustic coupler according to specified code of symbol. For type FSSE, cable adapter (15cm) is also provided.
  - Flow transmitter (Type: FSV) ×1: provided with U-bolt and nuts for pipe mount.
  - Signal cable (Type: FLY) 1 pair
- \* Resistance bulb (Pt100, 3-wire) is needed.
  - CD-ROM (contains instruction manual, loader software)
- For 2-pipe version
  - Detector (Type: FSS) ×2: provided with mounting fixture and acoustic coupler according to specified code of symbol. For type FSSE, cable adapter (15cm) is also provided.
  - Flow transmitter (Type: FSV) ×1: provided with U-bolt and nuts for pipe mount.
  - Signal cable (Type: FLY) 2 pairs
  - CD-ROM (contains instruction manual, loader software)

## ITEMS DESIGNATED ORDERING

1. Detector code symbols
2. Flow transmitter code symbols
3. Signal cable code symbols
4. Tag No. as necessary (up to 8 alphanumerical characters)
5. Code symbol for resistance bulb (Pt100, 3-wire)
6. If parameter setting is specified, send back the attached parameter specification table duly filled.

## OPTIONAL ACCESSORIES

	Name	Drawing No.
1	Silicone grease (G40M)	ZZP*45231N5
2	Silicone rubber (KE348V)	ZZP*45735N2
3	Silicone-free grease (HIGH-Z)	ZZP*TK7M0981P1
4	High-temperature grease	ZZP*TK7G7983C1

## Checked items before purchase

Following conditions may cause failure of the measurement or to reduce the accuracy by this flow meter.

Please consult and ask Fuji Electric for checking with actual equipment previously if you have hard to judge the appropriate application.

### 1) Fluid

- If fluid contains a large amount of bubbles (approx. 12vol% or more at 1m/s flow rate)
- If fluid has bad turbidity 10000(mg/L) or more,
- If fluid contains slurry or solid materials (about 5wt%)
- If flow rate is low Reynolds No.10000 or less,
- (reference: flow rate 5m<sup>3</sup>/h with ø100mm)
- If it is circulating oil, liquid medicine of low concentration, waste liquid and hot spring,

### 2) Pipe

- If inside pipe is rusty carbon steel pipe,
- If inside pipe having adhering substances and sediment
- If outer surface of cast-iron pipe is rough,
- If pipe wall is tick such as ruinous pipe, (PP material 15mm or more, PVDF material 9mm or more)
- If it is SGPW pipe,
- If lining pipe is removed from pipe, (Teflon, PVC, Glass)
- If it is rubber pipe,

### 3) Length of the straight pipe

- For accurate measurement, straight pipes are needed between up and down stream side of the measuring part.
- Please meet the straight pipe conditions according item4.

## Caution on use

- 1) Do not damage the sensor or signal mounted on the pipe.
- 2) Make sure to fill the fluid inside the pipe to measure .
- 3) When you use horizontal pipe, it is recommended to install the sensor horizontally.
- 4) When you use the grease as acoustic coupler to install the sensor for outdoor use, it is recommended to install the waterproof cover to prevent from the degradation.

## <Parameter specification table Measurement mode: 1-path/energy measurement> 1/2

Setting item		Initial value	Setting value	Setting range	
ID No		0000		ID No. is invalid when 0000 is selected.	
Language		Japanese		English, Japanese, German, French, Spanish	
Measurement mode		1 path		1 path, 2 path, 2 pipes	
Calculation output		—	—	Average, Addition, Sub (CH1-CH2), Sub (CH2-CH1)	
Operation mode		Normal		Normal, High speed	
System unit		Metric		Metric or Inch	
Measuring conditions	Unit	Flow unit	m <sup>3</sup> /h	L/s, L/min, L/h, L/d, kL/d, ML/d, m <sup>3</sup> /s, m <sup>3</sup> /min, m <sup>3</sup> /h, m <sup>3</sup> /d, km <sup>3</sup> /d, Mm <sup>3</sup> /d, BBL/s, BBL/min, BBL/h, BBL/d, kBBL/d, MBBL/d	
		Total unit	m <sup>3</sup>	mL, L, m <sup>3</sup> , km <sup>3</sup> , Mm <sup>3</sup> , mBBL, BBL, kBBL	
		Temperature unit	°C	°C, K, F	
		Thermal unit	MJ/h	MJ/h, GJ/h, BTU/h, kBTU/h, MBTU/h, kWh, MWh	
		Total unit (thermal)	MJ	MJ, GJ, BTU, kBTU, MBTU, kWh, MWh	
	Process setting	Outer diameter	60.00mm		6.00 to 6200.00mm
		Pipe material	PVC		Carbon steel, Stainless, PVC, Copper, Cast iron, Aluminum, FRP, Ductile iron, PEEK, PVDF, Acrylic and PP Pipe sound velocity (Sound velocity: [m/s, ft/s])
		Wall thickness	4.00mm		4.00mm
		Lining material	No lining		No lining, Tar epoxy, Mortar, Rubber, Teflon, Pyrex glass, PVC Lining S.V. (Sound velocity: [m/s, ft/s])
		Lining thickness	—		0.01 to 100.00mm
		Kind of fluid	Water		Water, seawater, dist. water, ammonia, alcohol, benzene, bromide, ethanol, glycol, kerosene, milk, methanol, toluol, lube oil, fuel oil, petrol and refrigerant R410 Fluid S.V. (Sound velocity: [m/s, ft/s])
		Viscosity	1.0038×10 <sup>-6</sup> m <sup>2</sup> /s		0.001 to 999.999×10 <sup>-6</sup> m <sup>2</sup> /s
		Sensor mounting method	V method		V method, Z method
		Sensor type	FSSA		FSSA/FSSG,FLS_12/FLS_22,FSSC,FSG_32,FSG_31/FSG_41,FSSC/FSG_50,FSSF/FSG_51, FSD12,FSSD/FSD22,FSSH/FSD32
		Energy measurement	Energy mode	Used	
	Operation mode		Cooling		Cooling, Heating, Air-conditioning
	Thermal coefficient for cooling		4.186		1.000 to 9.999
	Thermal coefficient for heating		4.123		1.000 to 9.999
	Output conditions	Damping		5.0 sec	0.0 to 100.0sec
		Low flow cut		0.15 m <sup>3</sup> /h	0 to 5m/s in terms of flow velocity
Analog output		Analog output 1 source channel	CH1 : Thermal flow		CH1: Flow rate, CH1: Thermal flow
		Analog output 2 source channel	CH1 : Flow rate		CH1: Flow rate, CH1: Thermal flow
		Kind	Flow rate		Velocity, Flow rate
		Range type	Single		Single, Auto 2, Bi-dir, Bi-dir Auto 2
		Full scale 1	15.000 m <sup>3</sup> /h		0, ±0.3 to ±32m/s in terms of flow velocity
		Full scale 2	0.000 m <sup>3</sup> /h		0, ±0.3 to ±32m/s in terms of flow velocity
		Full scale 1 (thermal)	0.000 MJ/h		0.000000 to 99999999
		Full scale 2 (thermal)	0.000 MJ/h		0.000000 to 99999999
		Hysteresis	10.00 %		0.00 to 20.00%
		Burnout (current)	Hold		Not used, Hold, Lower, Upper and Zero
Burnout timer		10 sec		10 to 900sec	
Output limit low		-20 %		-20 to 0%	
Output limit high		120 %		100 to 120%	
Total output		Total mode	Stop		Start, Stop, Reset
		Total rate	0 m <sup>3</sup>		0.000000 to 99999999
		Total preset	0 m <sup>3</sup>		0.000000 to 99999999
		Total rate (thermal)	0 MJ		0.000000 to 99999999
		Total preset (thermal)	0 MJ		0.000000 to 99999999
	Pulse width	50msec		5msec, 10msec, 50msec, 100msec, 200msec, 500msec, 1000msec	
	Burnout (total)	Hold		Not used, Hold	
Burnout timer	10 sec		10 to 900 sec		



## <Parameter specification table Measurement mode: 2-path> 1/2

Setting item		Initial value	Setting value	Setting range	
ID No		0000		ID No. is invalid when 0000 is selected.	
Language		Japanese		English, Japanese, German, French, Spanish	
Measurement mode		2 pipes		1 path, 2 path, 2 pipes	
Calculation output		Average		Average, Addition, Sub (CH1-CH2), Sub (CH2-CH1)	
Action mode		Normal		Normal, High speed	
System unit		Metric		Metric or Inch	
Measuring conditions	Unit	Flow unit	m <sup>3</sup> /h	L/s, L/min, L/h, L/d, kL/d, ML/d, m <sup>3</sup> /s, m <sup>3</sup> /min, m <sup>3</sup> /h, m <sup>3</sup> /d, km <sup>3</sup> /d, Mm <sup>3</sup> /d, BBL/s, BBL/min, BBL/h, BBL/d, kBBL/d, MBBL/d	
		Total unit	m <sup>3</sup>	mL, L, m <sup>3</sup> , km <sup>3</sup> , Mm <sup>3</sup> , mBBL, BBL, kBBL	
	Process setting	Outer diameter	60.00mm		6.00 to 6200.00mm
		Pipe material	PVC		Carbon steel, Stainless, PVC, Copper, Cast iron, Aluminum, FRP, Ductile iron, PEEK, PVDF, Acrylic and PP Pipe sound velocity (Sound velocity: [m/s, ft/s])
		Wall thickness	4.00mm		4.00mm
		Lining material	No lining		No lining, Tar epoxy, Mortar, Rubber, Teflon, Pyrex glass, PVC Lining S.V. (Sound velocity: [m/s, ft/s])
		Lining thickness	—		0.01 to 100.00mm
		Kind of fluid	Water		Water, seawater, dist. water, ammonia, alcohol, benzene, bromide, ethanol, glycol, kerosene, milk, methanol, toluol, lube oil, fuel oil, petrol and refrigerant R410 Fluid S.V. (Sound velocity: [m/s, ft/s])
		Viscosity	1.0038×10 <sup>-6</sup> m <sup>2</sup> /s		0.001 to 999.999×10 <sup>-6</sup> m <sup>2</sup> /s
	Sensor mounting method	V method		V method, Z method	
Sensor type	FSSA		FSSA/FSSG, FLS_12/FLS_22, FSSC, FSG_32, FSG_31/FSG_41, FSSE/FSG_50, FSSF/FSG_51, FSD12, FSSD/FSD22, FSSH/FSD32		
Damping		5.0 sec		0.0 to 100.0sec	
Low flow cut		0.15 m <sup>3</sup> /h		0 to 5m/s in terms of flow velocity	
Output conditions	Analog output	Analog output 1 source channel	CH1: Flow rate	CH1: Flow rate, CH2: Flow rate, CH3: Flow rate (Note2)	
		Analog output 2 source channel	CH2: Flow rate	CH1: Flow rate, CH2: Flow rate, CH3: Flow rate (Note2)	
		Kind	Flow rate	Velocity, Flow rate	
		Range type	Single	Single, Auto 2, Bi-dir, Bi-dir Auto 2	
		Full scale 1	15.000 m <sup>3</sup> /h	0, ±0.3 to ±32m/s in terms of flow velocity	
		Full scale 2	0.000 m <sup>3</sup> /h	0, ±0.3 to ±32m/s in terms of flow velocity	
		Hysteresis	10.00 %	0.00 to 20.00%	
		Burnout (current)	Hold	Not used, Hold, Lower, Upper and Zero	
		Burnout timer	10 sec	10 to 900sec	
		Output limit low	-20 %	-20 to 0%	
Output limit high	120 %	100 to 120%			
Total output	Total mode	Stop		Start, Stop, Reset	
	Total rate	0 m <sup>3</sup>		0.000000 to 99999999	
	Total preset	0 m <sup>3</sup>		0.000000 to 99999999	
	Pulse width	50msec		5msec, 10msec, 50msec, 100msec, 200msec, 500msec, 1000msec	
	Burnout (total)	Hold		Not used, Hold	
Burnout timer	10 sec		10 to 900sec		
Contact output	DO1 source channel	CH1		CH1, CH2, CH3	
	DO1 output type	Not used		Not used, +Total pulse, -Total pulse, Full scale 2, Alarm [All, Hardware fault, Process error] Flow switch <input type="checkbox"/> Flow SW high [                    ] <input type="checkbox"/> Flow SW low [                    ], Total switch [                    ], AO range over, Pulse range over, -Flow direction	
	DO1 output operation	Active ON		Active ON, Active OFF	
	DO2 source channel	CH1		CH1, CH2, CH3	
	DO2 output type	Not used		Same as "DO1 output type"	
	DO2 output operation	Active ON, Active OFF		Active ON, Active OFF	
	DO3 source channel	CH1		CH1, CH2, CH3	
	DO3 output type	Not used		Same as "DO1 output type"	
	DO3 output operation	Active ON		Active ON, Active OFF	
	DO4 source channel	CH1		CH1, CH2, CH3	
DO4 output type	Not used		Same as "DO1 output type"		
DO4 output operation	Active ON		Active ON, Active OFF		

<Parameter specification table Measurement mode: 2-path> 2/2

Setting item		Initial value	Setting value	Setting range
Output conditions	Display	Source channel of display 1st line	CH1	CH1, CH2, CH3
		Content of display 1st line	Flow rate (m <sup>3</sup> /h)	Velocity, Flow rate, Flow rate (%), +Total (Actual), +Total pulse, -Total (Actual), -Total Pulse
		Decimal point position of display 1st line	****.***	*.***** *.*.***** **.*.***** ***.*.***** ****.*.***** *****.*.*****
		Source channel of display 2nd line	CH2	CH1, CH2, CH3
		Content of display 2nd line	Flow rate (m <sup>3</sup> /h)	Velocity, Flow rate, Flow rate (%), +Total (Actual), +Total pulse, -Total (Actual), -Total Pulse
		Decimal point position of display 2nd line	****.***	*.***** *.*.***** **.*.***** ***.*.***** ****.*.***** *****.*.*****
Communication	Communication mode	RS-485		MODBUS
	Baud rate	9600bps		9600bps, 19200bps, 38400bps
	Parity	Odd		None, Odd, Even
	Stop bit	1 bit		1 bit, 2 bits
	Station No.	1		1 to 31
LCD	LCD backlight	ON		ON, OFF
	Lights-out time	5 min		0 to 99min

## <Parameter specification table Measurement mode: 2-pipe> 1/2

Setting item		Initial value	Setting value			Setting range	
ID No		0000				ID No. is invalid when 0000 is selected.	
Language		Japanese				English, Japanese, German, French, Spanish	
Measurement mode		2 pipes				1 path, 2 path, 2 pipes	
Calculation output		Average				Average, Addition, Sub (CH1-CH2), Sub (CH2-CH1)	
Action mode		Normal				Normal, High speed	
System unit		Metric				Metric or Inch	
Setting item		Initial value	Path 1 (CH1)	Path 2 (CH2)	Setting range		
Measuring conditions	Unit	Flow unit	m <sup>3</sup> /h			L/s, L/min, L/h, L/d, kL/d, ML/d, m <sup>3</sup> /s, m <sup>3</sup> /min, m <sup>3</sup> /h, m <sup>3</sup> /d, km <sup>3</sup> /d, Mm <sup>3</sup> /d, BBL/s, BBL/min, BBL/h, BBL/d, kBBL/d, MBBL/d	
		Total unit	m <sup>3</sup>			mL, L, m <sup>3</sup> , km <sup>3</sup> , Mm <sup>3</sup> , mBBL, BBL, kBBL	
	Process setting	Outer diameter	60.00mm			6.00 to 6200.00mm	
		Pipe material	PVC			Carbon steel, Stainless, PVC, Copper, Cast iron, Aluminum, FRP, Ductile iron, PEEK, PVDF, Acrylic and PP Pipe sound velocity (Sound velocity: [m/s, ft/s])	
		Wall thickness	4.00mm			4.00mm	
		Lining material	No lining			No lining, Tar epoxy, Mortar, Rubber, Teflon, Pyrex glass, PVC Lining S.V. (Sound velocity: [m/s, ft/s])	
		Lining thickness	—			0.01 to 100.00mm	
		Kind of fluid	Water			Water, seawater, dist. water, ammonia, alcohol, benzene, bromide, ethanol, glycol, kerosene, milk, methanol, toluol, lube oil, fuel oil, petrol and refrigerant R410 Fluid S.V. (Sound velocity: [m/s, ft/s])	
		Viscosity	1.0038×10 <sup>-6</sup> m <sup>2</sup> /s			0.001 to 999.999×10 <sup>-6</sup> m <sup>2</sup> /s	
		Sensor mounting method	V method			V method, Z method	
Sensor type	FSSA			FSSA/FSSG/FLS_12/FLS_22,FSSC,FSG_32, FSG_31/FSG_41,FSSE/FSG_50,FSSF/FSG_51, FSD12,FSSD/FSD22,FSSH/FSD32			
Setting item		Initial value	Path 1 (CH1)	Path 2 (CH2)	Calculated value (CH3)	Setting range	
Damping		5.0 sec			—	0.0 to 100.0sec	
Low flow cut		0.15 m <sup>3</sup> /h			—	0 to 5m/s in terms of flow velocity	
Output conditions	Analog output	Analog output 1 source channel	CH1: Flow rate				CH1: Flow rate, CH2: Flow rate, CH3: Flow rate (Note2)
		Analog output 2 source channel	CH2: Flow rate				CH1: Flow rate, CH2: Flow rate, CH3: Flow rate (Note2)
		Kind	Flow rate			Flow rate	Velocity, Flow rate
		Range type	Single				Single, Auto 2, Bi-dir, Bi-dir Auto 2
		Full scale 1	15.000 m <sup>3</sup> /h				0, ±0.3 to ±32m/s in terms of flow velocity
		Full scale 2	0.000 m <sup>3</sup> /h				0, ±0.3 to ±32m/s in terms of flow velocity
		Hysteresis	10.00 %				0.00 to 20.00%
		Burnout (current)	Hold				Not used, Hold, Lower, Upper and Zero
	Burnout timer	10 sec				10 to 900sec	
	Output limit low	-20 %				-20 to 0%	
Output limit high	120 %				100 to 120%		
Total output	Total mode	Stop				Start, Stop, Reset	
	Total rate	0 m <sup>3</sup>				0.000000 to 99999999	
	Total preset	0 m <sup>3</sup>				0.000000 to 99999999	
	Pulse width	50msec				5msec, 10msec, 50msec, 100msec, 200msec, 500msec, 1000msec	
Burnout (total)	Hold				Not used, Hold		
Burnout timer	10 sec				10 to 900sec		
Contact output	DO1 source channel	CH1				CH1, CH2, CH3	
	DO1 output type	Not used				Not used, +Total pulse, -Total pulse, Full scale 2, Alarm [All, Hardware fault, Process error] Flow switch <input type="checkbox"/> Flow SW high [            ] <input type="checkbox"/> Flow SW low [            ], Total switch [            ], AO range over, Pulse range over, -Flow direction	
	DO1 output operation	Active ON				Active ON, Active OFF	
	DO2 source channel	CH1				CH1, CH2, CH3	
	DO2 output type	Not used				Same as "DO1 output type"	
	DO2 output operation	Active ON				Active ON, Active OFF	
	DO3 source channel	CH1				CH1, CH2, CH3	
DO3 output type	Not used				Same as "DO1 output type"		
DO3 output operation	Active ON				Active ON, Active OFF		

<Parameter specification table Measurement mode: 2-pipe> 2/2

		Setting item	Initial value	Setting value	Setting range
Output conditions		DO4 source channel	CH1		CH1, CH2, CH3
		DO4 output type	Not used		Same as "DO1 output type"
		DO4 output operation	Active ON		Active ON, Active OFF
	Display	Source channel of display 1st line	CH1		CH1, CH2, CH3
		Content of display 1st line	Flow rate (m <sup>3</sup> /h)		Velocity, Flow rate, Flow rate (%), +Total (Actual), +Total pulse, -Total (Actual), -Total Pulse
		Decimal point position of display 1st line	****.***		*.***** ** ***** ***.****, ****.***, ***** ** ***** * *****
		Source channel of display 2nd line	CH2		CH1, CH2, CH3
		Content of display 2nd line	Flow rate (m <sup>3</sup> /h)		Velocity, Flow rate, Flow rate (%), +Total (Actual), +Total pulse, -Total (Actual), -Total Pulse
Decimal point position of display 2nd line	****.***		*.***** ** ***** ***.****, ****.***, ***** ** ***** * *****		
Communication	Communication mode	RS-485		MODBUS	
	Baud rate	9600bps		9600bps, 19200bps, 38400bps	
	Parity	Odd		None, Odd, Even	
	Stop bit	1 bit		1bit, 2 bits	
	Station No.	1		1 to 31	
LCD	LCD backlight	ON		ON, OFF	
	Lights-out time	5 min		0 to 99min	

Note1: When total pulse output has been selected for DO1, DO2, DO3, DO4 specify total pulse value and total pulse width so that conditions 1 and 2 shown below are satisfied.

$$\text{Condition 1 : } \frac{\text{Flow span-1} \cdot [\text{m}^3/\text{s}]}{\text{total pulse value} \cdot [\text{m}^3]} \leq 100[\text{Hz}] \quad \text{Condition 2 : } \frac{\text{Flow span-1} \cdot [\text{m}^3/\text{s}]}{\text{total pulse value} \cdot [\text{m}^3]} \leq \frac{1000}{2 \times \text{total pulse width} [\text{ms}]}$$

\* In the case of 2 ranges, perform calculations using either flow span-1 or flow span-2, whichever is greater.

Note1: The definition of channels

Channel 1 (CH1) is assigned for the output from path 1.

Channel 2 (CH2) is assigned for the output from path 2.

Channel 3 (CH3) is assigned for the calculation output (any of average value, added value, and subtracted value).

【備考】

⚠ Caution on Safety

\*Before using this product, be sure to read its instruction manual in advance.

**FE** Fuji Electric Co., Ltd.

Global Sales Section

Instrumentation & Sensors Planning Dept.

1, Fuji-machi, Hino-city, Tokyo 191-8502, Japan

<http://www.fujielectric.com>

Phone: +81-42-514-8930 Fax: +81-42-583-8275

<http://www.fujielectric.com/products/instruments/>

Information in this catalog is subject to change without notice.

Printed in Japan